



AIRBUS **EC** 500

24/7 HEALTHY VENTILATION

- Continuous trickle setting (24/7), silently eliminates stale/moist air which is replenished naturally with fresh air
- Three speed energy efficient EC motor ensures low operating costs
- Airbus EC 500 is ideal for ensuites, bathrooms and large open bathrooms
- Choose from a wide range of fascias
- Five year warranty



Green Fact:

The cost* of continuous running on 24/7 setting is less than \$1.00 per month. *Based on 42 cents per kWh.



Wireless Wall Controller: included



BOOST - 10 minutes for rapid steam/odour removal, then reverts back to 24/7



RUN - 20 minutes for excellent all round performance, then reverts back to 24/7



24/7 - Continuous trickle extraction creates a healthier living environment



Isolation Switch: not included

Can turn the unit ON / OFF and will default to the "RUN" setting when turned on

AIRBUS **EC** 500

24/7 HEALTHY VENTILATION



Premium high quality exhaust motor designed for 24/7 continuous ventilation for your home, with your choice of fascia.



Boost Run 24/7

MOTOR	Boost	Run	24/7
Air Flow:	510m ³ /h	380m ³ /h	70m ³ /h
Motor Power:	80w	35w	3w
Noise Level:	44dB(A)	40dB(A)	21dB(A)

INSTALLATION

Duct Outlet:	150mm
Ball Bearing Motor:	Yes
Draft Stopper:	Yes
Min. Install Depth:	220mm
Cut Out:	300mm
Power Input:	220-240V~50Hz
IP Rating:	IPX4
Installation:	Plug and Lead
Warranty:	5 years

SHIPPING

Packaging Size:	372 x 340 x 210mm
Gross Weight:	3kg
Carton Size:	705 x 375 x 519mm
Carton GW:	18kg
Carton Qty:	4 piece
Pallet Qty	80 pieces

INCLUDES

- 1 x Exhaust Motor Body
- 1 x Remote Control
- 1 x Plug & Lead
- 1 x Instruction Manual
- 1 x Warranty Card

Model	Style	Outer Carton	EAN13 Barcode
PVPXEC500	Airbus EC Motor 500	19339310014512	9 339310 014515

DIMENSIONS

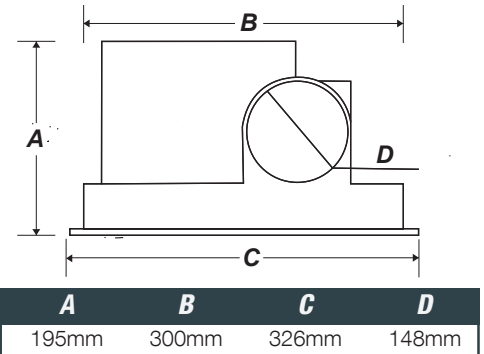

PRESSURE

PERFORMS WITH EXTENDED DUCTING

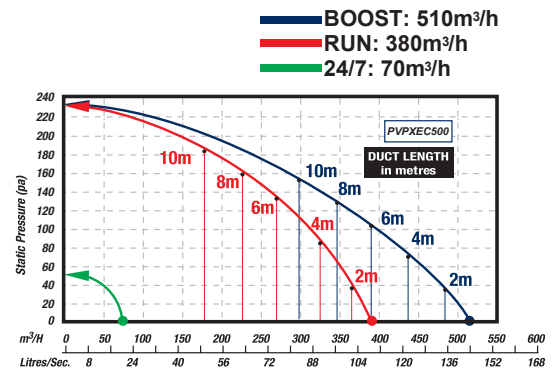

4 Capital Place, Carrum Downs, VIC, 3201, Australia

T: +61 3 9775 0556

E: sales@ventair.com.au

www.ventair.com.au |